

HV Test Set

(50/80/110 kV)

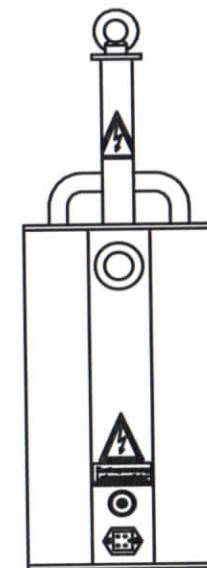

FORWARD

ADVICE FROM HAGENUK KMT GMBH

This user manual has been conceived as a description and reference work. It is intended to help you to answer questions and solve problems as quickly as possible. Should you have problems, please first read the user manual with care. To do this, make use of the index and read the relevant section carefully. Also check all the relevant connections.

If your questions still remain unanswered, please contact the following address:

Hagenuk KMT Kabelmeßtechnik GmbH

Röderaue

D - 01471 Radeburg / Dresden

TELEFON: +49 / 35208 / 84 - 0

TELEFAX: +49 / 35208 / 84 249

SERVICE-HOTLINE:

TELEFON +49 / 35208 / 84 211

TELEFAX: +49 / 35208 / 84 250

e-mail: kmt@kmt.de

internet: <http://www.kmt.de>

© Hagenuk KMT GmbH

All rights reserved. No part of this manual may be photocopied or reproduced in any other form without the prior written consent of Hagenuk KMT GmbH. We reserve the right to change the contents of this manual without notice. Hagenuk KMT GmbH shall not be liable for any technical or typographical errors or omissions in this manual. Nor shall Hagenuk KMT GmbH be liable for any loss which is directly or indirectly attributable to delivery, performance or use of this material.

TERMS AND CONDITIONS OF WARRANTY

Hagenuk KMT Kabelmeßtechnik GmbH grants the buyer a warranty on products sold by Hagenuk KMT in accordance with the terms and conditions listed below.

Hagenuk KMT guarantees that Hagenuk KMT products are at the time of their delivery free from defects in workmanship or materials which substantially reduce their value or serviceableness. This warranty does not cover faults in supplied software. During the warranty term Hagenuk KMT will repair defective parts or replace them with new or as-new parts (with the same operability and service life as new parts) at its option.

Additional warranty claims, in particular claims arising from consequential loss, cannot be asserted. All parts and products replaced under the terms of this warranty become the property of Hagenuk KMT.

Warranty claims on Hagenuk KMT lapse 12 months after the delivery date. Parts supplied by Hagenuk KMT within the framework of the warranty are also covered by this warranty for the remaining warranty term, but for no less than 90 days.

Warranty measures are undertaken exclusively through Hagenuk KMT or a special service shop which is authorized by Hagenuk KMT Kabelmeßtechnik GmbH.

Claims under the terms of this warranty are subject to the buyer notifying Hagenuk KMT of defects without delay and no later than within 10 days of the delivery date in the case of perceptible defects.

This warranty does not cover defects or damage caused by the products being exposed to conditions which are not in accordance with the specifications, being stored, transported or used incorrectly, or being serviced or installed by agencies not approved by Hagenuk KMT. The warranty does not cover damage owing to natural wear and tear, force majeure or connection to external parts.

Hagenuk KMT is only liable for claims for damages arising from the violation of claims for repair or replacement in the event of gross negligence or intent. Any liability for ordinary negligence is ruled out.

CONTENST

1.GENERAL.....	3
1.1 Safety instructions	3
1.2 Indications used in the description.....	5
2 TECHNICAL DESCRIPTION.....	9
2.1 Description of the set	9
2.1.1 Set versions.....	9
2.1.2 Scope of supply	9
2.1.3 Use of the set	11
2.2 Design of the set	12
2.3 Function	13
2.4 Specifications.....	14
3. PREPARATION FOR USE	17
3.1 Operating requirements.....	17
3.2 Assembling the discharge rod.....	19
3.3 Connecting the test equipment	19

4 OPERATING INSTRUCTIONS.....	23
4.1 Controls and displays.....	23
4.2 Operating procedure.....	25
4.2.1 Setting the operating parameters.....	25
4.2.2 Performing measurements.....	25
4.2.3 Ending testing.....	27
4.2.4 Safety measures.....	29
5 CARE, MAINTENANCE AND REPAIR	31
EC-Declaration of conformity	32

CHAPTER 1

GENERAL

1. GENERAL

The HV Test Set is a generator of high direct voltages.

The insulation of cables, electrical plant and plant components can be tested for electric strength with this set. The insulation resistance of test objects can be determined by measuring current and voltage using integrated measuring instruments.

Thanks to its small size and low weight, the HV Test Set, which consists of a operation unit and an HV unit, is portable and can be used directly on site. The clear arrangement of controls and displays makes the set comfortable to handle.

A special protective ground circuit ensures a high level of safety.

1.1 Safety instructions

All persons involved in the transport, installation, operation, maintenance and repair of this system must have read this user manual carefully.

The system and its accessories are in accordance with the current state of safety technology at the time of delivery. Owing to the work process involved, however, there may be parts of the system and its peripherals which cannot be given optimum protection without an unreasonable reduction in function and usability.

The following safety instructions must be complied with.

GENERAL INSTRUCTIONS

Work on this system and its peripherals must only be performed by qualified and/ or trained staff. Other persons must be kept away.

This user manual must be available for the supervisory, operating and maintenance staff to refer to.

Improper use may endanger life and limb, the system and connected equipment, as well as the efficient functioning of the system.

Always use correct tools in perfect condition.

Checks must be made to ensure that the relevant safety regulations are being complied with.

Only operate the system if it is in technically perfect condition.

No non-original parts may be used for the system and its peripherals, as the necessary safety will not be guaranteed. No mode of working which detracts from the safety of the system must be used.

The user is under an obligation to report any changes in the system to the supervisor responsible without delay.

ELECTROTECHNICAL INSTRUCTIONS

The system and all additional equipment must be connected properly. The relevant DIN and VDE regulations must be complied with.

Maintenance work must only be carried out when the system is switched off (dead) and then only by qualified and/ or trained staff.

1.2

INDICATIONS USED IN THE DESCRIPTION

Important instructions concerning personal protection, work safety and technical safety are indicated as follows:

WARNING:

Warning indicates work and operating procedures which must be complied with in full to exclude the possibility of persons being put at risk. This includes instructions concerning particular dangers when handling the system.

Attention:

Attention indicates work and operating procedures which must be complied with in full to prevent the system/ peripherals from being damaged or destroyed

N.B.:

N.B. indicates special technical requirements to which the user must pay particular attention when using the system.

CHAPTER 2

TECHNICAL DESCRIPTION

2. TECHNICAL DESCRIPTION

2.1 Description of the set

2.1.1 Set versions

Three set versions with different maximum voltages are available:

HV Test Set 50: max. DC test voltage 50 kV

HV Test Set 80: max. DC test voltage 80 kV

HV Test Set 110: max. DC test voltage 110 kV

2.1.2 Scope of supply

The scope of supply includes the following:

		50 kV	80 kV	110 kV
Item	Description	Article no.	Article no.	Article no.
00001	Operation unit	950200	950200-1	950200-2
00002	Leather case for operation unit	02104	02104	02104
00003	High-voltage unit	950201	950201-1	950201-2
00004	HV attachment	950203	950203	950203

Continued on page 10

Table continued from page 9:

Item	Description	50 kV	80 kV	110 kV
		Article no.	Article no.	Article no.
00005	Connecting cable, high-voltage unit to operation unit (permanently attached to operation unit)	60005	60005	60005
00006	Cable 3 (blue), lead for high-voltage unit	60003	60003	60003
00007	Cable 2, operation ground cable, high-voltage unit to station ground, black	60002	60002	60002
00008	Cable 1, ground cable, operation unit to station ground, green/yellow	60001	60001	60001
00009	Discharge rod	23101-1	23101-2	23101-3
00010	Cable 4, ground cable for discharge rod	60004	60004	60004
00011	Case for discharge rod	02106	01206	02106
00012	User manual	06001	06001	06001
00013	Service kit	950204	950204	950204
00014	Packing	02004	02004	02004

Table 2.1 Scope of supply

2.1.3 Use of the set

The HV TEST SET is used for electrical testing of power cables and plant with direct voltage:

Areas of application include:

- Testing newly laid cables before initial use
- Testing disconnected cables
- Regular cable testing
- Testing electrical equipment

The following test voltages are prescribed by DIN 57298 Part / VDE 0298 Part 1 for testing with direct voltage:

Nominal voltage Vo/U in kV/kV	0.6/1	3.6/6	6/10	12/20	18/30
DC test voltage in kV	5.6-8	20-29	34-48	67-96	76-108

Table 2.2 Test voltages

WARNING: Owing to the high voltages which occur, special safety measures are required. These are explained in later sections of the manual (see also chapter 1).

2.2 Design of the set

The HV TEST SET consists of the operation unit and the high-voltage unit. All the controls and displays are arranged clearly in the operation unit. The high-voltage transformers, measuring dividers and rectifiers are housed in the high-voltage unit, which is filled with oil (see fig. 2.1).

The two units are linked by a five-pole cable which is connected to the back of the operation unit.

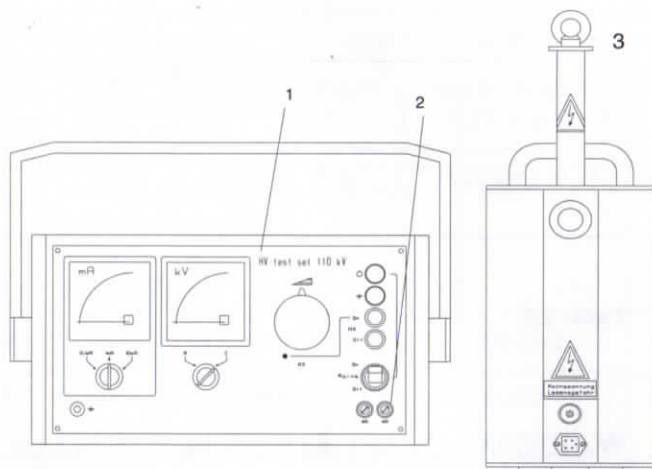

- 1 Operation unit with controls and displays
- 2 Primary fuses
- 3 High-voltage unit

Fig. 2.1 Operation unit and high-voltage unit

2.3 Function

Before the set can be used, the operation unit and high-voltage unit have to be grounded properly.

When the high-voltage adjuster is set to zero, the test voltage can be switched on at the press of a button and increased continuously between 0 V and the nominal voltage.

This voltage is generated in the high-voltage unit using transformers with rectifiers connected in outgoing circuit.

The condition of the test object with regard to electric strength and insulation quality can be determined from the values for test voltage and leakage current displayed on the operation unit.

2.4 Specifications

Power supply	Observe version! 230 V +/- 10%, 50 Hz (Standard) 115 V +/- 10%, 60 Hz
Power consumption	max. 0.9 kW
DC output voltage	
HV Test Set 50 kV	0...50 kV
HV Test Set 80 kV	0...80 kV
HV Test Set 110 kV	0...110 kV
	negative polarity, infinitely variable
Measuring range, voltage	
HV Test Set 50 kV	0...50 kV
HV Test Set 80 kV	0...80 kV
HV Test Set 110 kV	0...110 kV
Measuring range, current	0.1 mA/1 mA/10 mA
Measuring accuracy	±2%

DC output current at maximum	
DC output voltage	
HV Test Set 50 kV	6 mA
HV Test Set 80 kV	5 mA
HV Test Set 110 kV	4 mA
Overcurrent tripping	
HV Test Set 50 kV	≥ 8 mA
HV Test Set 80 kV	≥ 7 mA
HV Test Set 110 kV	≥ 6 mA
Climatic and mechanical stresses as per DIN IEC 68	
Operating temperature	-25°C...+55°C
Storage temperature	-40°C...+70°C
Mechanical strength	
Vibration stress	as per DIN 68 T2-6, test group C
Weight of operation unit	13.5 kg (approx. 29¾ lbs)
Weight of high-voltage unit	
50 kV version	17.0 kg (approx. 37½ lbs)
80 kV version	18.5 kg (approx. 40¾ lbs)
110 kV version	20.0 kg (approx. 44 lbs)
120 kV version	20,5 kg (approx. 45 lbs)
Degree of protection as per DIN VDE 0470 Part 1	
Operation unit	IP 40
High-voltage unit	IP 65
High-voltage unit at terminals	IP 00
Maximum discharge capacitance for ground and discharge rod	6 µF at maximum DC output voltage

CHAPTER 3

PREPARATION FOR USE

3. PREPARATION FOR USE

3.1 Operating requirements

Once the operation unit has been removed from the leather case, its carrying handle can be adjusted by exerting gentle sideways pressure on the button on either side in the joint area.

The connecting cables are in the back cover of the operation unit.

The high-voltage unit must always be set up in an upright position and secured against accidental contact during operation.

WARNING: The stipulated clearance between the high-voltage unit and grounded or live parts must be complied with.

CAUTION: Warning notices reading

DANGER!
HIGH- TENSION

When the high-voltage unit is set up in accordance with the above instructions, it must be placed in close proximity to the test object, so that the ground and high-voltage cables can be kept as short as possible.

When the equipment is set up in the field, it must be placed outside the cable trench and protected against dirt and moisture.

The operation unit should be set up inside the cordon at a distance of 3 m from the high-voltage unit, preferably at operating height.

3.2 Assembling the discharge rod

Before the HV Test Set is started up, the ground and discharge rod has to be assembled. The individual parts should be taken out of the protective case and assembled as shown in fig. 3.1.

It should be noted that the discharge rod varies depending on which version of the test set is used (50, 80 or 110 kV).

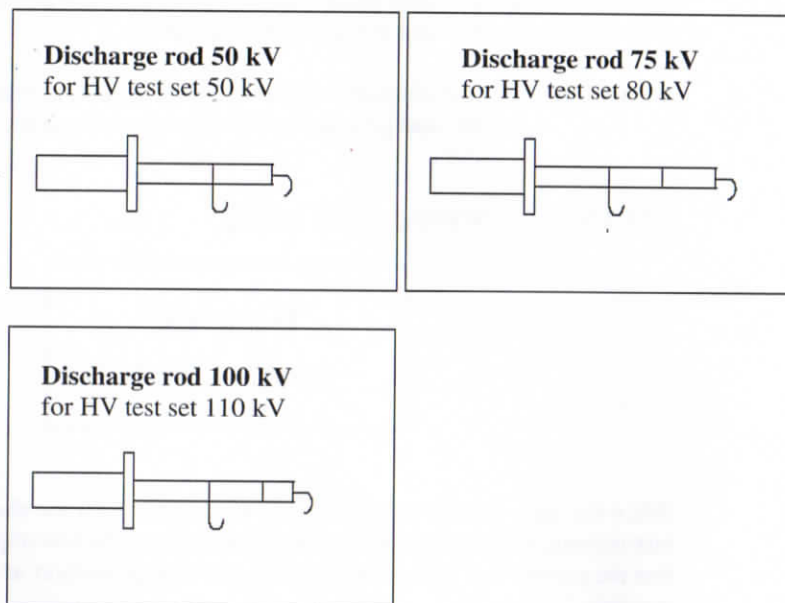

Caution: Follow assembly instructions

Fig. 3.1 Assembling the ground and discharge rod

3.3 Connecting the test equipment

NB: Before connecting the equipment, make sure that the oil level is visible in the centre of the oil-level lens [3]. If not, no measuring must be done.

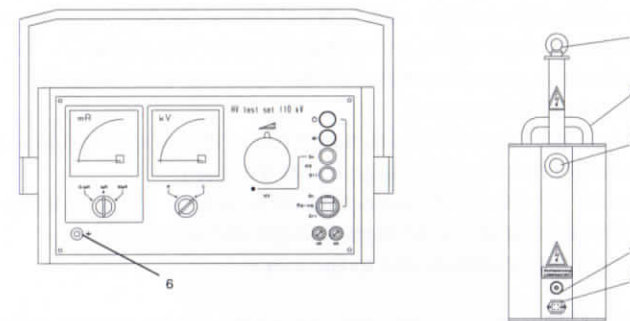

- 1 HV attachment with high-voltage terminal
- 2 Carrying handle
- 3 Oil-level lens
- 4 Ground terminal
- 5 Terminal for connecting cable to operation unit
- 6 Ground terminal for operation unit

Fig. 3.2 Operation unit and high-voltage unit with terminals

Before the test equipment is connected, safe isolation from supply must be established and safeguarded in accordance with DIN VDE 0105 must be complied with.

The test equipment should be connected in the following order:

1. Ground and short-circuit the conductor of the test object that is not going to be tested (connect to station ground or auxiliary ground point). In the case of ungrounded test objects, the test set can only be used if an auxiliary ground is provided.
2. Establish a conductive connection between the station/auxiliary ground and the ground terminal of the high-voltage unit [4].
3. Screw the high-voltage attachment [1] onto the high-voltage unit and connect the high-voltage terminal [1] to the test object.
4. Connect the ground terminal of the operation unit [6] to the station/auxiliary ground.
5. Connect the ground and discharge rod to the ground terminal of the test object and hold the discharge rod at the ready.
6. Connect the five-pole connecting cable, which is permanently attached to the operation unit, to the high-voltage unit (terminal [5]).
7. Connect the operation unit to the mains.

ATTENTION: The blue connecting cable between high- voltage terminal and test object is to use as uninsulated overhead cable.

Example (Fig. 3.3)

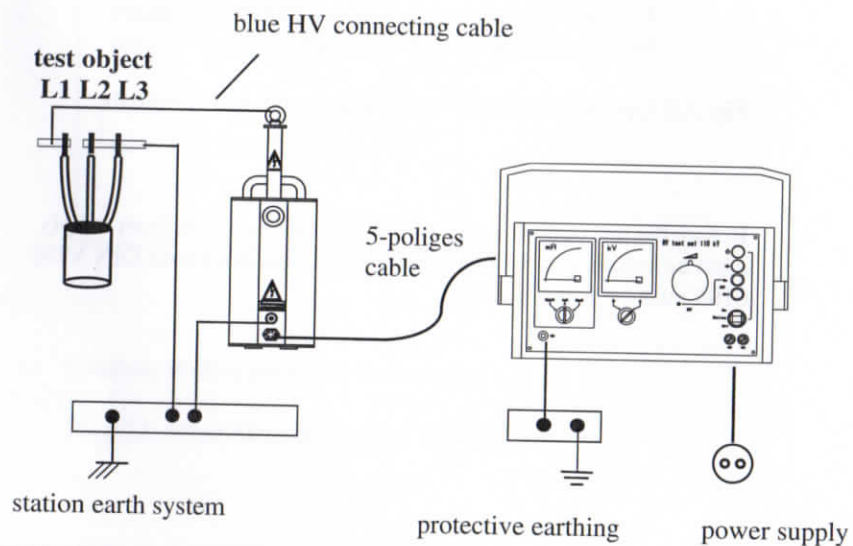

CHAPTER 4

OPERATING INSTRUCTION

4. OPERATING INSTRUCTIONS

4.1 Controls and displays

The controls and displays needed to operate the HV Test Set are on the front of the operation unit.

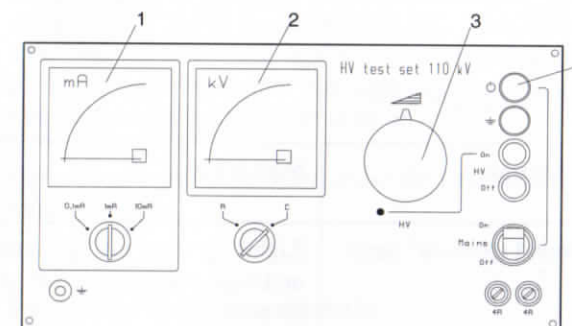

Fig. 4.1 Front of the operation unit

The following tables explain the controls:

Item	Description	Remarks
1	Ammeter	Displays the current flowing through the test object
2	Voltmeter	Displays the voltage connected to the test object
3	HV adjuster	Adjuster for the high-voltage with forced zero position
4	"Unit on" lamp	Lights up when the unit is switched on with the mains switch [8] and mains voltage is connected

Table 4.1 Controls and displays (part 1)

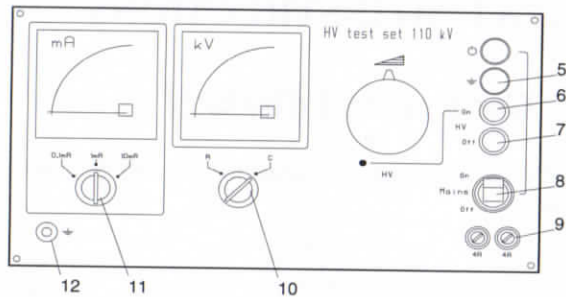

Fig. 4.2 Front of the operation unit

Item	Description	Remarks
5	"Ground terminal" lamp	Lights up when the operation unit and high-voltage unit are grounded properly
6	"HV on" button	Button for switching on the high voltage
7	Illuminated "HV off" button	Illuminated button for switching off the high voltage (lights up when the high-voltage is switched on)
8	Mains switch	
9	Primary fuses	
10	"Load" selector switch	Switches between resistive and capacitive load
11	"Current measuring range" selector switch	Switches between the current measuring ranges
12	Ground terminal	Connection of the operation unit to ground potential

Table 4.2 Controls and displays (part 2)

4.2 OPERATING PROCEDURE

4.2.1 Setting the operating parameters

When measuring the insulation resistance of plant or plant components with primarily resistive content, the "Load" selector switch (fig. 4.2 [10]) has to be set to "R". This is necessary if an exact reading of the measured value is to be obtained. If cables, plant or plant components with primarily capacitive content are tested, the selector switch must be set to "C".

Before starting measurement, select the largest current measuring range (10 mA).

4.2.2 Performing measurements

When the mains switch is turned on, the white pilot lamp lights up. If the equipment is grounded properly, the green pilot lamp also lights up.

If this does not happen, the operation unit still has to be grounded with cable 1 (ground cable for operation unit to station ground).

This pilot lamp signals proper connection of the station and protective grounds independently of the high voltage being connected.

The equipment will only work when both lamps are lit.

The green "HV on" button switches the high voltage on if the voltage regulating transformer is in zero position at left stop (second switching operation, interlock, forced zero position).

The red illuminated "HV off" button lights up at the same time, indicating that the "high voltage is switched on".

The test voltage can now be set by slowly turning the adjuster anticlockwise. While doing this, remember to follow the increase in voltage and current on the instruments.

Once the prescribed test voltage has been reached, the leakage current of the test object can be measured by operating the selector switch for the current measuring range (0.1 mA, 1 mA, 10 mA).

The following guide values can be quoted for paper-insulated mass-impregnated cables:

Nominal cable voltage (kV)	Test voltage (kV)	Leakage current per wire in $\mu\text{A}/\text{mm}^2$	
		permitted	min. achievable
6	35	500	23
10	50	700	30
20	80	700	80
30	110	700	100

Table 4.2 Guide values for leakage currents

Measurement must be repeated at least three times during testing. The test time should be at least 15 min. and max. 30 min. The tendency of the leakage current should be followed.

The following are all signs of increased wear to the test object:

1. The leakage current indicated is greater than the permitted leakage current
2. The leakage currents of different wires in the same cable differ by more than 1:3
3. The leakage current measured after approx. 60 seconds is less than the leakage current at the end of the test time

If the maximum operating current is exceeded, the overcurrent trip will respond and disconnect the equipment from the mains.

If this happens, the test object is defective.

If the nominal test voltage of the equipment is exceeded by approx. 5 kV, the overvoltage trip will respond. If this happens, the high voltage will have to be switched back on (set the high-voltage adjuster to zero first).

4.2.3 Ending testing

Once testing is complete, turn the voltage down and switch the equipment off.

When the test voltage has dropped by about 10%, discharge the test object by holding the ground and discharge rod against the high-voltage terminal of the high-voltage unit.

WARNING: Make absolutely sure that the ground and discharge rod is grounded properly.

Only capacitances of less than 6 μF may be discharged, in which case the cooling time for the discharge rod is approx. 30 minutes.

The discharge process of the test object can be followed on the measuring instrument.

Hang the ground and discharge rod up in the middle of the high-voltage attachment.

This short-circuits the connected test object, the middle hook of the grounding and discharge rod has to be attached to the high-voltage terminal of the high-voltage unit

The equipment can now be unplugged from the mains.

Finally ground/short-circuit the test object itself.

4.2.4 Safety measures

Please also follow the safety instructions in chapter 1.

The set must only be operated by electricians in accordance with DIN VDE 0105. It must only be operated in areas which have been secured and/ or cordoned off and marked in accordance with DIN VDE 0104 and DIN VDE 0105.

In an emergency, the high voltage must be switched off by a second operator pressing the red "HV off" button, and the set must be discharged and short-circuited with the discharged rod.

WARNING: Never put equipment with moisture condensation into operation.

Reliable grounding of the high-voltage unit, the operation unit and the ground and discharge rod is always necessary in addition to adequate protection against electric shock.

WARNING: Care must be taken during testing that the far end is also reliably protected against electric shock.

Be aware that residual charges may still be present after discharge in the case of capacitive tests.

WARNING: Parallel cables may also still be charged after testing.

Always check the oil level (oil level in the centre of the oil-level lens) before testing.

CHAPTER 5

CARE; MAINTENANCE AND REPAIR

5. CARE, MAINTENANCE AND REPAIR

The repair work which can be done on the HV TEST SET by the user is limited to the replacement of fuses and lamps. Fuses, lamps and tools are included in the service kit.

Repairs to the high-voltage unit are not generally permitted.

No more testing must be done if the oil level drops.

If the HV TEST SET is defective, the complete set must be sent in for repair, as the operation unit is matched to the high-voltage unit (interchangeability not guaranteed).

The HV TEST SET is test equipment and as such must be handled and looked after with care.

Moisture, external soiling, direct sunlight and ambient temperatures in excess of 55°C must be avoided.

ATTENTION: The high-voltage unit must only be transported in an upright position.

EC-Declaration of conformity

CE Mark

We, the company

**Hagenuk KMT
Kabelmeßtechnik GmbH
Röderaue
D-01471 Radeburg**

declare in our responsibility, that the product

**HV test set 50 kV
HV test set 80 kV
HV test set 110 kV**

is in conformity with the regulations of the Council of European Community for equalization of the rule and regulation of the member states about electromagnetic compatibility.(EMC-regulation 89/336/EWG).

This EC- declaration of conformity is the result of tests conducted by the quality assurance department of Hagenuk KMT Kabelmeßtechnik GmbH according to article 10 of the regulation and in accordance with the basic standards EN 50081-1 radio emission, EN 50082-2 Distortion resistivity, the product standard EN 55011 and the basic standard EN 60801-2 Electrostatical discharges and IEC 1000-4-4 fast transient disturbances.

Radeburg, 19. of December 1995

Dr.Krieger
Managing Director